

Installation, Operation and Maintenance Instructions



SAFEHOLD® XPL SERIES PERMANENT MAGNETIC ON/OFF LIFTING MAGNETS

ERIEZ HEADQUARTERS: 2200 ASBURY ROAD, ERIE, PA 16506-1402 U.S.A.
WORLD AUTHORITY IN SEPARATION TECHNOLOGIES

Introduction

This manual details the proper steps for installing, operating and maintaining the Eriez SafeHold® XPL Series Lifting Magnet.

Careful attention to these requirements will assure the most efficient and dependable performance of this equipment.

If there are any questions or comments about the manual, please call Eriez at 814/835-6000 for SafeHold® XPL Series Lifting Magnet assistance.



CAUTION - STRONG MAGNET

This equipment includes one or more extremely powerful magnetic circuits. The magnetic field may be much stronger than the Earth's background field at a distance several times the largest dimension of the equipment.

- **If you use a heart pacemaker or similar device you must never approach the equipment because your device may malfunction in the magnetic field, with consequences up to and including death.**
- **To avoid serious pinch-type injuries caused by objects attracted to the magnet, keep all steel and iron objects well away from the equipment. Do not allow hands, fingers, and other body parts to be caught between the equipment and nearby steel or iron objects.**
- **Keep credit cards, computer disks, and other magnetic storage devices away from the equipment because magnetically stored information may be corrupted by the magnetic field.**
- **Keep electronic devices, such as computers or monitors, away from the equipment because exposure to the magnetic field may result in malfunction or permanent damage to such devices.**

Contact Eriez if you have a question regarding these precautions.



CAUTION

Safety labels must be affixed to this product. Should the safety label(s) be damaged, dislodged or removed, contact Eriez for replacement.

Table of Contents

SAFEHOLD® XPL SERIES LIFTING MAGNET

DESCRIPTION.....	4
CONSTRUCTION	4
INSTALLATION	4
INSPECTION	5
TESTING	6
MAINTENANCE.....	7
OPERATION.....	7
SPECIFICATIONS	11
PARTS LIST	12



Description

The Eriez SafeHold XPL Series magnet is a permanent type magnet in which the magnetic field is mechanically turned off and on similar to an electromagnet. Several sizes of manually actuated magnets are available.

The magnets are designed and built to ASME B30.20 Standards For Below-The-Hook Lifting Devices. The figure below shows the features of a typical SafeHold Lifting Magnet.

! CAUTION

This manual covers the factors to be considered by the user in most common lifting applications. However, not every application may be addressed.

If the instructions are not clear, or if some aspect of your lifting application is not covered in this manual, or if you have any questions about magnetic lifting, call Eriez at (814) 835-6000.

Installation

All lifting magnets are packed for shipping in a manner that provides adequate protection for the pole faces and other critical areas. XPL Series SafeHolds do not present any potential hazards for magnetic attraction in the "as shipped" condition.

The magnet is typically attached to an overhead lifting device properly rated to handle the maximum magnet capacity. A properly designed or selected clevis, shackle, chain hook or strap is attached through the lifting eye.

The rated load (capacity) of the lifting magnet is clearly marked on the lifting magnet or on a tag attached to it where it is visible. This rating refers to this instruction manual for information relating to decreases in rating due to load thickness, load alloy, load surface conditions, load length or width, attitude of load, portion of lifting magnet face in contact with load and/or load temperature. For more information see *Operation - Factors Affecting Lifting Capacity*. The marked capacity is based a specific load for which the rating applies.

Construction

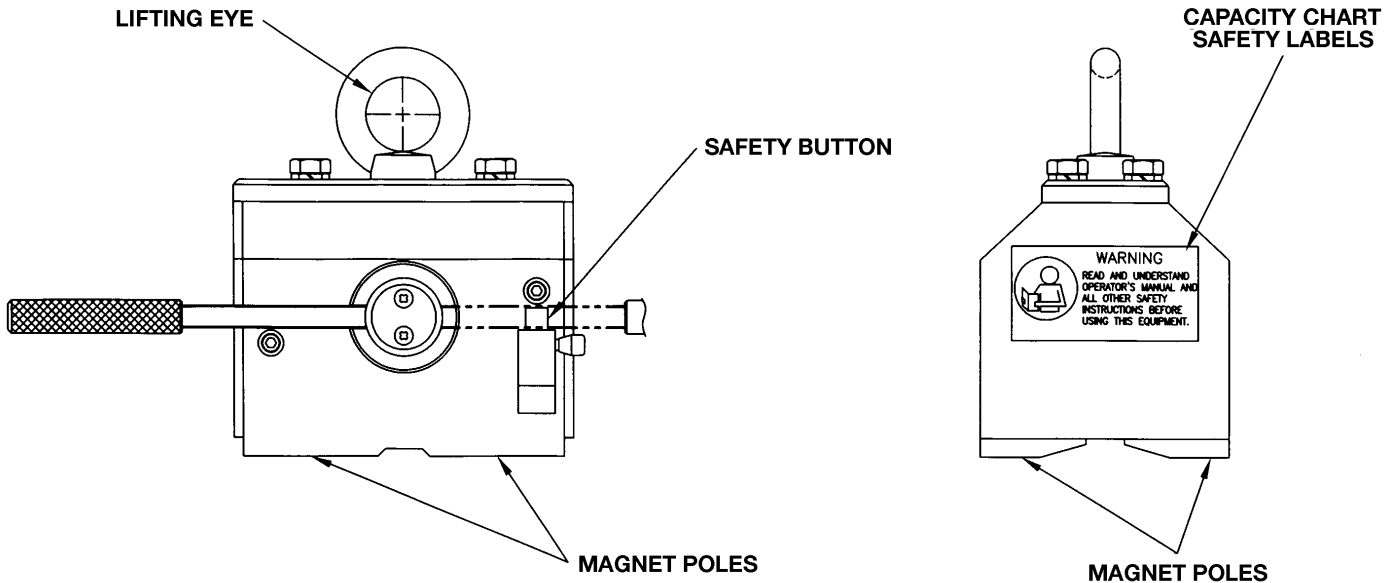

FIGURE 1



Inspection

Inspection Classification

Initial Inspection

- New and reinstalled lifting magnets shall be inspected by a designated person prior to initial use to verify compliance with applicable provisions of this manual.
- Altered, repaired, or modified lifting magnets shall be inspected by a designated person. The inspection may be limited to the provisions affected by the alteration, repair, or modification, as determined by a qualified person.

Inspection Intervals

Inspection procedures for lifting magnets in regular service are divided into three general classifications, based upon the intervals at which the inspections shall be performed. The intervals, in turn, are dependent upon the nature of the critical components of the lifting magnet and the degree of their exposure to wear, deterioration, or malfunction. The three general classifications are designated as every lift, frequent, and periodic, with respective intervals between inspections as defined below.

- Every Lift Inspection. Visual examination by the operator before and during each lift made by the lifting magnet.
- Frequent Inspection. Visual examination by the operator or other designated persons with records not required.
 - Normal service – monthly
 - Heavy service – weekly to monthly
 - Severe service – daily to weekly
 - Special or infrequent service – as recommended by a qualified person before and after each occurrence
- Periodic Inspection. Visual inspection by a qualified person making records of apparent external conditions to provide the basis for a continuing evaluation.
 - Normal service – yearly
 - Heavy service – quarterly, unless external conditions indicate that disassembly should occur to permit detailed inspection
 - Severe service – monthly, unless external conditions indicate that disassembly should occur to permit detailed inspection

- Special or infrequent service – as recommended by a qualified person before the first occurrence and as directed by the qualified person for any subsequent occurrences

Every Lift Inspection

Items such as the following shall be inspected by the operator before and/or during every lift for any indication of damage as specifically indicated, including observations during operation for any damage that might occur during the lift:

- Lifting magnet face and surface of the load for foreign materials and smoothness.
- Condition and operation of the control handle of a manually controlled permanent magnet.
- Condition and operation of indicators and meters when installed.

Frequent Inspection

Items such as the following shall be inspected for damage at intervals as defined above, including observations during operation for any indications of damage that might appear between inspections. A qualified person shall determine whether any indications of damage constitute a hazard or will require more frequent inspection. For all lifting magnets, inspect:

- Structural and suspension members for deformation, cracks, or excessive wear on any part of the lifting magnet.
- Lifting magnet face for foreign materials and smoothness.
- Condition of lifting bail or sling suspension.
- Condition and operation of control buttons.
- Condition and operation of indicators and meters, where applicable.
- Cracked housings, welds, and loose bolts.
- Labels and markings.

Installation (cont.)

Periodic Inspection

Complete inspections of lifting magnets shall be performed and recorded at intervals as defined above. Any deficiencies, such as those listed below, shall be examined by a qualified person and determination made as to whether they constitute a hazard. These inspections shall include the requirements of the above and, in addition, items such as the following:

- All members, fasteners, locks, switches, warning labels, and lifting parts shall be inspected for deformation, wear, and corrosion.

Lifting Magnets Not In Regular Use

A lifting magnet that has been idle for a period of 1 month or more is to be given an inspection in accordance with above before being placed into service.

Inspection Records

Dated inspection reports shall be made on critical items, such as those listed in periodic inspections. Records should be available to appointed personnel for each periodic inspection and when the lifting magnet is either modified or repaired.

Repairs

Any indications of damage disclosed by the inspection requirements shall be corrected according to the procedures outlined below before operation of the lifting magnet is resumed.

Testing

Operational Tests

- New and reinstalled lifting magnets shall be tested by a qualified person, or a designated person under the direction of a qualified person, prior to initial use to verify compliance with applicable provisions of this manual, including, but not limited to, the following:
 - Moving Parts
 - Latches
 - Stops
 - Switches
 - Any control devices
 - Alarms

- Altered, repaired, or modified lifting magnets shall be tested by, or under the direction of, a qualified person. The test may be limited to the provisions affected by the alteration, repair, or modification, as determined by a qualified person with guidance from Eriez.
- All indicator lights, gages, horns, bells, alarms, pointers, and other warning devices shall be tested.
- Dated reports of all operational tests shall be filed.

Load Test

- Prior to initial use, all new, modified, or repaired lifting magnets shall be tested by a qualified person and a record be furnished confirming the load rating of the lifting magnet.
 - General application lifting magnets shall be required to satisfy the rated breakaway force test. The rated load of the lifting magnet shall be less than 50% of the rated breakaway force measured in this test.
 - Special application lifting magnets shall be required to comply with the application breakaway force test. The specified application load shall be less than 50% of the application breakaway force measured in this test.
- The breakaway force test shall establish the force required to vertically remove the lifting magnet from a low carbon, rolled steel plate of the minimum thickness stated by the lifting magnet manufacturer. The portion of this plate that is in contact with the lifting magnet shall not exceed 125 in. (3.2×10^{-3} mm) and be flat within 0.002 in./ft. (0.05 mm/m), without exceeding 0.005 in. (0.127 mm) total. The full operating face of the lifting magnet shall be in contact with the steel plate, which shall be between 60°F (15°C) and 120°F (50°C).
- The application breakaway force test shall establish the application breakaway forces of the lifting magnet under the variety of loading conditions for which the lifting magnet is specified. The details of this test should be supplied by Eriez.
- Altered, repaired, or modified lifting magnets shall be tested by, or under the direction of, a qualified person. This test may be limited to the provisions affected by the alteration, repair, or modification, as determined by a qualified person with guidance from Eriez.



Maintenance

Maintenance Procedure

- Before adjustment and repairs are started on a lifting magnet, the following precautions shall be taken.
 - A lifting magnet removed for repair shall be tagged "Out of Service."
- Only qualified personnel shall work on lifting magnet when adjustments and tests are required.
- Replacement parts shall be at least equal to the original manufacturer's specifications.
- After adjustments and repairs have been made, the lifting magnet shall not be returned to service until it has been inspected according to the above procedure.
- Dated records of repairs and replacements should be made available.

Adjustments and Repairs

Any hazardous conditions disclosed by the inspection requirements shall be corrected before normal operation of the lifting magnet is resumed. Adjustments and repairs shall be done under the direction of, or by, a qualified person.

Operation

WARNING

Because the operator inherently works very close to the magnet when using the SafeHold XPL, **THE WORKPIECE SHOULD NEVER BE DROPPED FROM MID-AIR.** Release of the workpiece from the magnet may be uneven for any of several reasons, causing rotation of the workpiece and an unpredictable fall path, resulting in serious personal injury or property damage.

The ability of the SafeHold XPL Series to operate without being dependent on an external power supply provides an inherent safety feature. Although the XPL Series can be substituted for electromagnets in many instances it is not intended to replace them.

To activate the magnet turn the handle from OFF to ON. Lock the handle in position with the safety latch. **(NOTE: The magnet must be placed on the workpiece before the handle is rotated.)**

The workpiece can be released by moving the safety latch and rotating the switch handle to the OFF position after the workpiece has been set down or in a supported condition. (See Figure 2).

The handle extension **must be fastened in place** when operating the magnet. **Do not operate with the handle unfastened.**

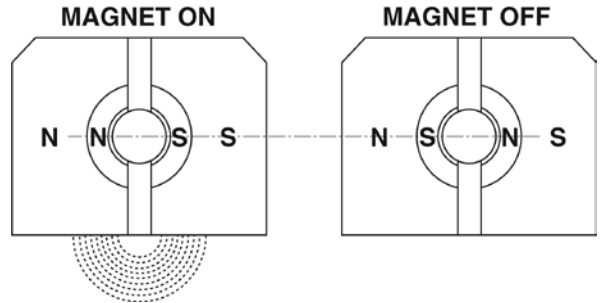

Rotatable element is turned 180° from OFF to ON, or vice versa, to energize or de-energize the magnet.

FIGURE 2

SafeHold XPL Series Magnetic Circuit

SafeHold magnets have a safety latch that locks when the magnet is turned on. This is for the operator's benefit and should never be removed. If damaged, it should be replaced.

CAUTION

The handle on manually operated SafeHold magnets will tend to override the operator's control through part of the stroke. Failure to grip the handle firmly could result in injury.

Operators

The lifting magnet shall be operated only by a trained, designated person.

Qualifications

Qualifications for operators of lifting magnets are as follows:

- The operator shall be instructed in the use of the lifting magnet by a designated person. Instructions should include, but not be limited to, the following:
 - Application of the lifting magnet to the load and adjustments, if any, that adapt the lifting magnet to various sizes or kinds of loads.

Operation (cont.)

- Instructions in any special operations or precautions.
- The manufacturer's suggested operating procedures.
- Condition of the load required for operation of the lifting magnet, such as, but not limited to, balance, surface cleanliness, flatness, bending, and load thickness.
- Storage of the lifting magnet to protect it from damage.
- Not exceeding the rated load of the lifting magnet nor the capacity of the hoisting equipment by the combined weight of the load, lifting magnet, and rigging.
- The proper attachment of adapters to lifting magnet for special load handling.
- The operator shall demonstrate the ability to operate the lifting magnet as instructed before assuming responsibility for using the lifting magnet.

Conduct of Lifting Device Operators

- The operator shall give attention to the operation of the lifting magnet during a lifting sequence.
- When physically or otherwise unfit, an operator shall not engage in the operation of the lifting magnet.
- Operators shall be responsible for those operations under their direct control. Whenever there is any doubt as to safety, the operator shall consult with the designated person before handling the load.
- The operator shall respond only to instructions from designated persons. However, the operator shall obey a stop order at all times, no matter who gives it.
- The operation of the lifting magnet shall be observed before use and during a shift. Any deficiency observed shall be carefully examined by a designated person. If the deficiency constitutes a hazard, the lifting magnet shall be removed from service and tagged "Out of Service." Any indication of a hazardous condition shall be reported to a qualified person for evaluation.
- The operator shall be familiar with standard hand signals when applicable.

- The operator shall land any attached load and store the lifting magnet before leaving the lifting magnet.
- All controls shall be tested by the operator before use during a shift. If any controls do not operate properly, they should be adjusted or repaired before operations are begun.
- The operator shall not ride, or allow others to ride loads or the lifting magnet.
- The operator and other personnel shall stay clear of the load. Loads shall be guided by pushing or pulling at the edge in such a manner as to avoid endangering hands or other body parts as the load is lowered, or if it drops.

Lifting Device Operating Practices

- Lifting magnets shall be operated only by the following qualified personnel:
 - Designated persons.
 - Trainees under the direct supervision of a designated person.
 - Maintenance and test personnel, when it is necessary in the performance of their duties.
 - Inspectors (lifting magnet).
- The lifting magnet shall not be loaded in excess of its rated load or handle any load for which it is not designed.
- The lifting magnet shall be applied to the load in accordance with the instruction manual.
- Before lifting, the operator shall make sure that lifting magnet ropes or chains are not kinked and that multiple part lines are not twisted around each other.
- Care should be taken to make certain the load is correctly distributed for the lifting magnet being used.
- The temperature of the load should not exceed the maximum allowable limits of the lifting magnet.
- The lifting magnet shall be brought over the load in such a manner as to minimize swinging.
- Care shall be taken that there is not sudden acceleration or deceleration of the load.
- Do not allow load or lifting magnet to come into contact with any obstruction.
- The operator shall avoid carrying the load over people.



- The lifting magnet shall not be used for side pulls or sliding the load unless specifically authorized by a qualified person.
- The lifting magnet face and the lifting magnet contact area on the load shall be clean.
- The load to be lifted shall be within the lifting magnet's rated load (capacity) or application load (capacity) and lifting equipment rated load (capacity).
- The operator shall observe all meters and indicators on the lifting magnet to confirm proper operation prior to making a lift.
- Before starting the lift, the operator shall lift the load a few inches to establish that the load is securely attached to the lifting magnet.
- All Magnets. Before raising the load more than 2" (50 mm), any adjustable input control should be switched to the "full on" position and remain in this position until the load is removed from the lifting magnet.
- Before lifting, the operator should confirm that the control handle is in the "lift" or "on" position and the control handle latch is operating.
- Before lifting, the operator shall warn people near the lift.
- The operator should not reenergize the lifting magnet until it has been placed in contact with the next load to be lifted. Prematurely energizing the lifting magnet could cause unwanted materials to be attracted to the lifting magnet.
- The operator shall not leave suspended loads unattended.

Miscellaneous Operating Practices

- An operator shall not use a lifting magnet that is tagged "Out of Service" or otherwise designated as nonfunctioning.
- "Out of Service" tags on lifting magnet shall not be removed without the approval of the person placing them or an authorized person.
- The lifting magnet, when not in use, should be stored at an assigned location.
- Caution should be taken that operating markings or tags shall not be removed or defaced. Missing or illegible markings or tags shall be replaced.

Factors Affecting Lifting Capacity

- **Load Thickness.** The magnetic flux flowing from a lifting magnet into a load increases as the thickness of the load increases. Consequently, as a lifting magnet's lifting capacity is a function of this flux, the lift capacity increases with load thickness. For every lifting magnet, there is a critical load thickness where all of the lifting magnet's available flux flows into the load and the lift capacity reaches maximum.
- **Load Alloy.** Many alloys of iron do not accept, magnetic flux as easily as do low carbon steels. Consequently, loads of such alloys will not accept all of the flux available in the lifting magnet, which reduces the lifting magnet's lift capacity.
- **Load Surface Conditions.** Anything that creates an air gap or nonmagnetic separation between a lifting magnet and the load reduces the flux flowing from the lifting magnet into the load, which reduces the lifting capacity of a lifting magnet. A rough surface finish, paper, dirt, rust, paint, and scale produce such gaps.
- **Load Length or Width.** As the length or width of the load increases, the load begins to deflect and to peel at the lifting magnet face. This may create an air gap between the load and the lifting magnet, which reduces the lifting capacity as described above.
- **Attitude of Load.** As the attitude of the surface of the load to which a lifting magnet is attached (lifting surface) changes from horizontal to vertical, the lifting capacity of the lifting magnet reaches a minimum and becomes dependent upon the coefficient of friction of the lifting surface.
- **Portion of Lifting Magnet Face in Contact with Load.** The full face of the lifting magnet must contact the load if the lifting magnet is to achieve maximum capabilities.
- **Load Temperature.** The temperature of the load can cause damage to the lifting magnet and, if high enough, even change the magnetic characteristics of the load. The standard magnet is designed to operate in a -14°F to 122°F (-25°C to 50°C) environment. The load temperature can be between -40°F and 175°F (-40°C and 80°C).

Operation (cont.)



The lifting magnet face and the lifting magnet contact area on the load must be clean.



The operator should avoid carrying the load over people.



Nobody must be allowed to stand on top of lifted workpiece.



Do not allow load or magnet to come into contact with any obstruction.

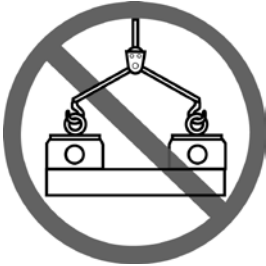

No hooking of two lifting magnets without the use of a properly designed spreader beam.



Care should be taken to make certain the load is correctly distributed for the lifting magnet being used.



Avoid placing the magnet in shear.



Avoid uneven lifts.

Specifications

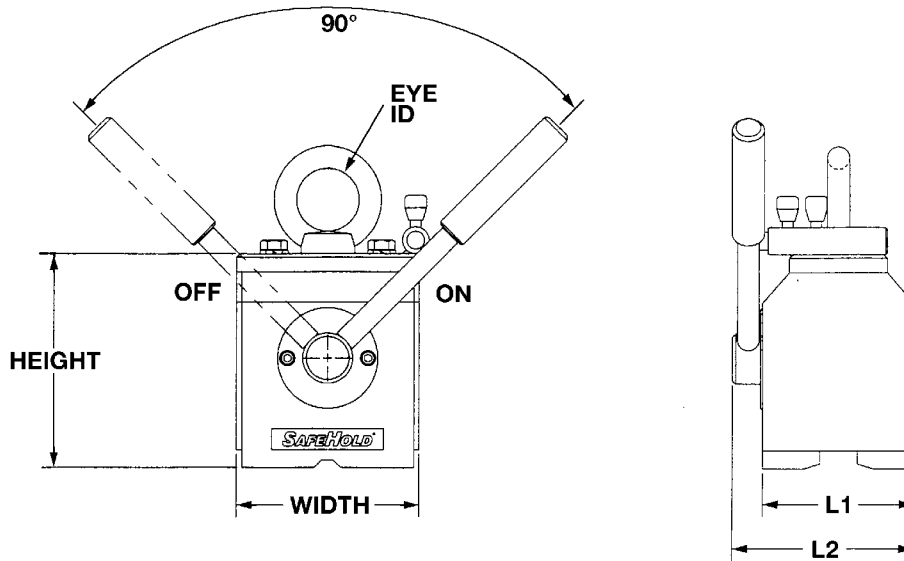

Model Number	Dimensions											
	L1		L2		Width		Height		Eye ID		Weight	
	in	mm	in	mm	in	mm	in	mm	in	mm	lbs	kg
XPL-4/3	3-3/8	85	4	102	4	102	4-11/16	119	1-3/8	35	16	7
XPL-8/6	4-1/2	115	5-13/16	147	6-1/16	154	4-11/16	119	1-3/8	35	33	15
XPL-15/19	5-5/16	135	6-5/8	167	7-1/4	184	5-7/8	149	1-1/2	40	55	25
XPL-24/16	5-5/16	135	7	178	9-1/2	242	6-7/8	175	1-15/16	50	88	40
XPL-30/24	5-5/16	135	7	178	10-3/8	263	7-12/16	199	2-5/16	60	111	50
XPL-50/40	6-1/8	155	8-1/4	210	13-1/2	343	9-7/8	251	2-3/4	70	212	96

Model Number	Max Lifting Capacities				Max Breakaway Force				Minimum Dia. When Lifting Rounds w/o Pole Shoes		Maximum Dia. When Lifting Rounds w/o Pole Shoes		Test Plate Thickness	
	Flat Steel (2:1 SF)		Round Steel (2:1 SF)		Flat Steel		Round Steel*							
	lbs	kg	lbs	kg	lbs	kg	lbs	kg	in	mm	in	mm	in	mm
XPL-4/3	400	181	300	136	800	362	600	272	2-1/2	64	5	127	1-1/4	32
XPL-8/6	800	362	600	272	1,600	724	1,200	543	3	76	9	229	1-3/4	45
XPL-15/19	1,500	680	900	408	3,000	1,360	1,800	815	3	76	10	254	1-3/4	45
XPL-24/16	2,400	1,088	1,600	725	4,800	2,177	3,200	1,448	4	102	15	381	2	51
XPL-30/24	3,000	1,360	2,400	1,088	6,000	2,721	4,800	2,177	4	102	15	381	2	51
XPL-50/40	5,000	2,268	3,700	1,678	10,000	4,536	8,000	3,629	6	152	18	457	2	51

Note:

1. These are actual ratings on flat, clean, polished steel plate.
2. Maximum attractive force of each model is approximately twice the Lifting Capacity.
3. Thin sheets, rough and irregular surfaces, odd shapes and scale all affect holding power adversely and must be considered in establishing a safety factor.

* Based on maximum recommended material diameter.

Parts List

Contact Eriez Parts Department for current parts list
800-345-4946.

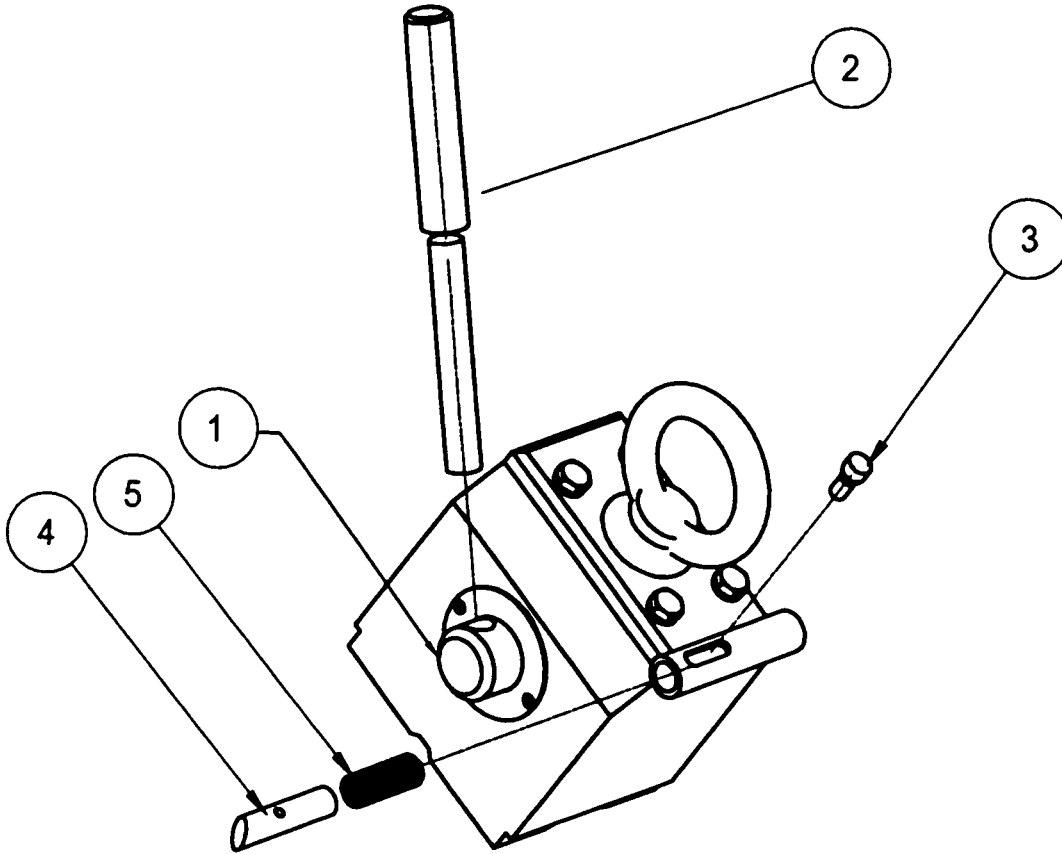

Note: Some safety warning labels or guarding may have been removed before photographing this equipment.
Eriez and Eriez Magnetics are registered trademarks of Eriez Manufacturing Co, Erie, PA

©2014 Eriez Magnetics All Rights Reserved



World Authority in Separation Technologies

Headquarters: 2200 Asbury Road, Erie, PA 16506-1402 U.S.A.

Telephone: 814-835-6000 • 800-345-4946 • Fax: 814-838-4960 • International Fax: 814-833-3348

Web Site: <http://www.eriez.com> e-mail: eriez@eriez.com

Manufacturing Facilities: AUSTRALIA • BRAZIL • CANADA • CHINA • INDIA • JAPAN • MEXICO • SOUTH AFRICA • UNITED KINGDOM • UNITED STATES